

VAN 2 | Design Roberto Pamio

Lampada da incasso in vetro satinato, eseguita nei colori: azzurro, blu, bianco, rosa, verde Nilo, verde e cristallo trasparente.

Semi-recessed glass fixture available in the following colors: light blue, white, cobalt blue, rose, jade green, aquamarine and crystal.

Einbauleuchte aus satiniertem Glas in den Farben hellblau, blau, weiß, rosa, nilgrün und grün erhältlich. Neue Varianten: kristall klar.

Spot encastré en verre satiné disponible dans les couleurs en les coloris: azur, bleu, blanc, rose, vert Nil ou vert. Nouveau variante en cristal transparent.

Empotrable en vidrio satinado disponible en los colores: azul claro, azul oscuro, blanco, rosa, verde Nilo y verde. Nueva variante en vidrio transparente.

Встроенный светильник из сатирированного стекла расцветок: Голубая, Синяя, Белая, Розовая, Зеленая Нил, Зеленая и прозрачный хрусталь.

VAN 2

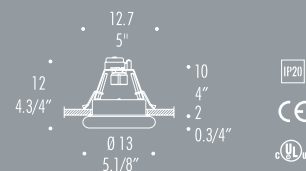

DIC max 1x50W-12V-GU5.3
DIC max 1x50W-250V-GU10

1,6 Kg - 4 lbs
foro 9,5 - Opening 3.3/4"

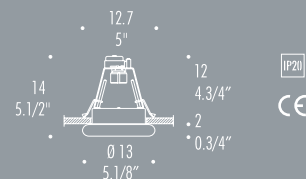

max 1x7W-LED-230V-GU10
max 1x11W-FLUORESCENT-230V-GU10
1x35W-MR-HQI-Brite Spot 230V-GX10

Quantitativo minimo
per le versioni colore
n. 20 pz. cad.

Minimum quantity
for colour finishes
nr. 20 pieces for each.



B: Bianco
White



L: Verde Nilo
Acquamarine



U: Blue
Cobalt blue



C: Cristallo
Crystal



H: Rosa
Rose



Q: Azzurro
Pale blue



V: Verde
Jade green

Dati tecnici pag. 374 > 379

Technical data available
on pages 374 > 379



VAN 2



pag. 344 > 345

0,7 Kg - 1.5 lbs
foro 9,5 - Opening 3.3/4"



VAN 2 - GU 5,3 - 50W 38°

Lux			
h	E max	E med	
1.00	2190	1253	
2.00	548	313	
3.00	243	139	
4.00	137	78	
5.00	88	50	

Gamma Angle

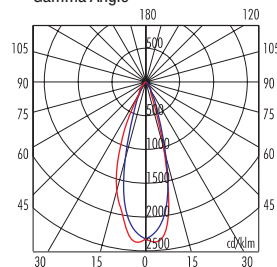

IP20 CE

IP43 CE eUL

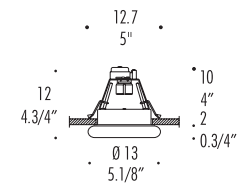
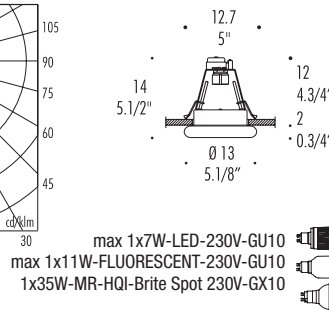

max 1x7W-LED-230V-GU10
max 1x11W-FLUORESCENT-230V-GU10
1x35W-MR-HQI-Brite Spot 230V-GX10

DIC max 1x50W-12V-GU5.3
DIC max 1x50W-250V-GU10

VAN



pag. 346 > 347

1,35 Kg - 3 lbs
foro 9,5 - Opening 3.3/4"



VAN - 52W incandescent

Lux			
h	E max	E med	
1.00	164	48	
2.00	41	12	
3.00	18	5	
4.00	10	3	
5.00	7	2	

Gamma Angle

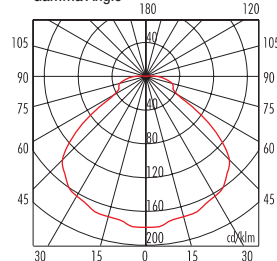

IP43 CE eUL

K max 1x52W-250V-E27
K max 1x60W-250V-E27-R63
AL max 1x50W-250V-E27-PAR20
1x35W-220/240V-GX10-MT35
Brite Spot-HQI

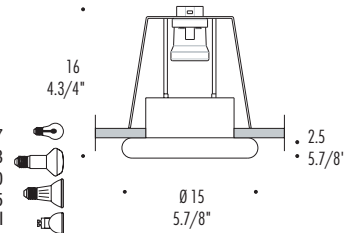

PRINCIPALI CARATTERISTICHE MAIN FEATURES

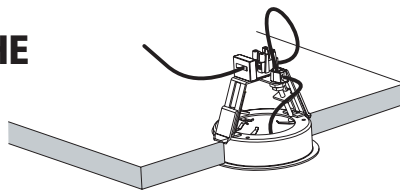

Controsoffitto in spessore

Thick false ceiling / Starke Hängendecke
Epaisseur faux-plafons / Cielorraso fino (grosso)

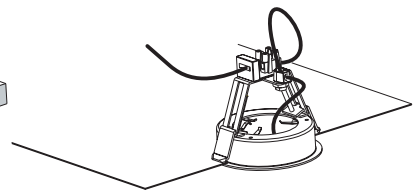

Controsoffitto sottile

Thin false ceiling / Dünne Hängendecke /
Faux-plafond fin / Cielorraso fino

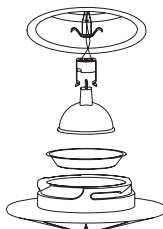

1 Montatura metallica unica per tutti i modelli. **2** Versatilità di installazione in qualsiasi tipo di controsoffitto e di solai pieni. **3** Rapidità di installazione: la montatura copre le eventuali irregolarità del foro. **4** Installazione anticipata della montatura: il vetro può essere montato a lavori ultimati. **5** Intercambiabilità del vetro. **6** Facilità di sostituzione della lampadina. **7** Semplicità di rimozione della montatura.

1 One metal fitting for all models. **2** Installation possible in any type of ceiling or false ceiling. **3** Quick installation: the fitting covers any irregularities in the hole. **4** Fitting installed first: the glass may be inserted at the very end. **5** Interchangeable glass. **6** Easy bulb replacement. **7** Easy-to-remove fitting.

1 Eine einzige Fassung aus Metall für alle Modelle. **2** Installationsvielseitigkeit auf jeder Art von Hängendecken und Massivdecken. **3** Schnelle Installation: die Fassung verdeckt eventuelle Unregelmäßigkeiten der Bohrung. **4** Die Fassung wird zuerst montiert: das Glas kann nach beendeten Arbeiten montiert werden. **5** Austauschbarkeit der Gläser. **6** Einfaches Auswechseln der Glühbirne. **7** Einfache Entfernung der Fassung.

1 Monture en métal unique pour tous les modèles. **2** Universalité d'installation sur tous types de faux-plafonds et de planchers pleins. **3** Rapidité d'installation: la monture couvre les éventuelles irrégularités du trou. **4** Installation anticipée de la monture: le verre peut être monté à la fin des travaux. **5** Verre interchangeable. **6** Ampoule facile à remplacer. **7** Monture peut être facilement enlevée.

1 Unica estructura en metal para todos los modelos. **2** Facilidad de instalación en cualquier tipo de cielorraso y de desvános llenos. **3** Rapidez de instalación: la estructura cubre las posibles irregularidades del agujero. **4** Instalación anticipada de la estructura: el cristal puede montarse al final de los trabajos. **5** Intercambiabilidad del cristal. **6** Facilidad de cambio de la bombilla. **7** Facilidad de extracción de la estructura.

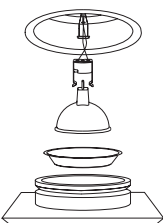

Montatura in metallo con innesto a scatto. Medesimo foro di incasso degli altri modelli. Stesse caratteristiche descritte nei punti 1 - 2 - 3 - 4 - 5 - 6 - 7.

The opening in the ceiling however will be the same as for the other type trims. Same characteristics as in point n. 1 - 2 - 3 - 4 - 5 - 6 - 7.

Fassung aus Metall mit Federinstöcken. Dieselbe Eintrittöffnung der ander Modelle. Dieselbe in den 1 - 2 - 3 - 4 - 5 - 6 - 7. Punkten beschriebenen Merkmale.

Monture en métal avec greffe à déclic. Même orifice d'arrivée des autres modèles. Mêmes caractéristiques décrites dans les points 1 - 2 - 3 - 4 - 5 - 6 - 7.

Montura en metal con inserción a presión. Igual perforación de entrada de los otros modelos. Igualas características descritas en los puntos 1 - 2 - 3 - 4 - 5 - 6 - 7.